

GEISSELE[®] AUTOMATICS LLC

WE MANUFACTURE CONFIDENCE

MI6/M4/ARI5/ARI0
HI-SPEED
NATIONAL MATCH
AND
DESIGNATED MARKSMAN
RIFLE TRIGGER

U.S. PAT 7,331,136 OTHER PATENTS PENDING

READ THIS FIRST

Firearm safety is YOUR responsibility. You must memorize and put into practice the **4 Rules of Firearm Safety.**

1. Assume every weapon is loaded.
2. Keep your finger off the trigger until you are ready to shoot.
3. Do not let the muzzle point at anything you are not willing to destroy.
4. Know your target and what is beyond.

The Geissele Automatics National Match/DMR Trigger will lighten the trigger pull relative to a standard trigger. This lightened trigger pull will make the weapon easier to discharge. You must recognize and accept this fact before installing this National Match trigger. If you do not want a lighter than standard trigger pull or are not willing to accept responsibility for your weapon's safety, the safety of yourself and the safety of those around you, do not install this trigger. Geissele Automatics recommends installation by a certified gunsmith only.

DISASSEMBLY AND INSPECTION OF LOWER RECEIVER

Unload weapon and make safe.

Remove upper receiver assembly, pistol grip, safety detent spring, safety detent follower, safety and existing trigger/hammer assembly. The GA trigger cannot be installed in the receiver unless the safety is removed.

Clean lower receiver.
Check and make sure your Hi-Speed trigger includes the following components:

- Trigger/Disconnecter assembly (referred to as "trigger")
- Hammer assembly (referred to as "hammer")
- Ancillaries
 - bottle of GA No. 1 Oil
 - vial of GA No. 2 Grease
 - fitting pin
 - three Allen Keys (0.050, 1/16 and 5/64")
 - oversized hammer pin (small pin triggers only)

Check the dimensions of the hammer pin hole: Try and insert a GA pin into the hole for the hammer pin from the left and right side. The pin should not be able to enter with finger pressure. If the pin can enter the hammer pin hole the hole in the receiver is worn or oversized. The GA pins are designed for a light interference/tap fit on nominal receiver pin holes. If necessary, use the Oversized Hammer Pin for the hammer pin hole. The Oversized Hammer Pin is 0.0005" larger than the 0.1558" diameter GA pin. It is acceptable for the trigger pin to have a looser fit than the hammer pin.

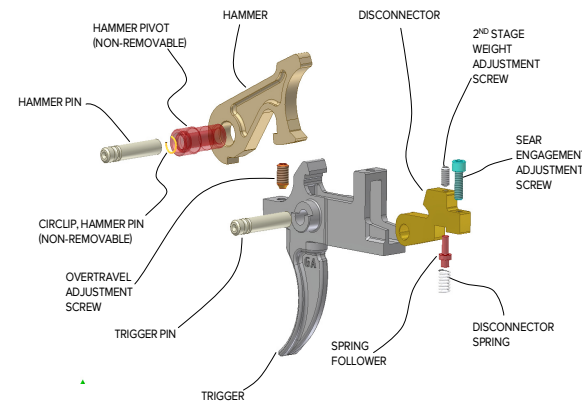

Figure 1 – Exploded View, Trigger Assembly

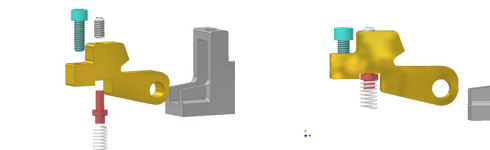

Figure 2 –Disconnector sub-assembly (disassembled and assembled)

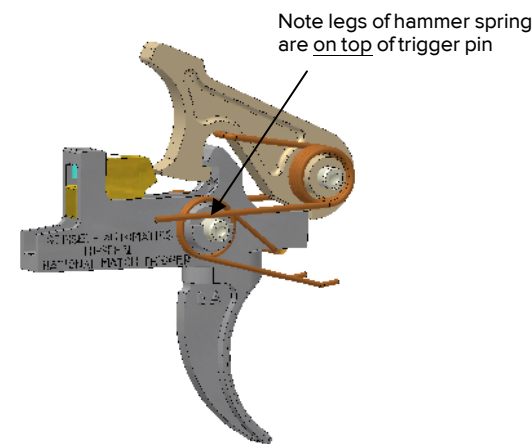

Figure 3 - Trigger/Hammer Assembly

INSTALLATION OF TRIGGER

Lubricate the trigger and disconnecter pin bores with the supplied GA No.1 Oil. Insert trigger into lower receiver while making sure the trigger spring legs rest against the bottom

of the receiver well and extend forward from the trigger. See FIG 3.

Now slip the supplied 3-1/4" long Fitting Pin into the receiver trigger pin hole and through the trigger assembly. Place your finger on the disconnecter and hold the front end down so the pin can fit through the disconnecter bore. Initial fitting of trigger and 1st stage weight adjustment should be done with the GA Fitting Pin or standard AR15 pins, not with the trigger and hammer pins. The pins supplied with the Geissele Automatics trigger are sized for a light tap fit into the receiver. Using the GA Fitting Pin or standard AR15 pins for initial fitting will make the assembly process easier.

CHECK TRIGGER FIT WITH SAFETY

Temporarily install the safety, safety detent follower, safety detent spring and pistol grip. (Note: The safety cannot be inserted into the receiver if the trigger is in the un-cocked position. Since the hammer is not installed yet just pivot the trigger away from the safety so the safety can slide past the back of the trigger.) Pull the trigger and see if the sides of the trigger fit into the cutout in the safety without touching or dragging on the safety. By necessity, the rear part of the GA trigger is wider than the stock trigger to accommodate the adjustment screws and related mechanism. This makes the fit of the trigger into the safety sensitive to the width of the safety slot and the axial position of the safety in the receiver (which is controlled by the detent hole position and is why the pistol grip needs to be installed during the fit process). If the trigger drags on the safety it is recommended to remove metal from the sides of the safety slot with a Dremel tool equipped with a thin cutoff wheel. Do not remove any metal from the bottom of the safety slot where the trigger stops on the safety. See Fig 4. If there is any doubt if the trigger is rubbing against the safety remove the disconnecter sub-assembly and the trigger spring. Re-check trigger fit with the bare trigger component. This will make any rubbing easier to detect.

If you detect a 'rough' first stage the trigger is rubbing. Recheck fit in safety, check for rubbing where the trigger bow goes through the slot in the bottom of the receiver and check at the right rear of the trigger where it comes close to the receiver wall. Remove areas of interference on the receiver, not the trigger.

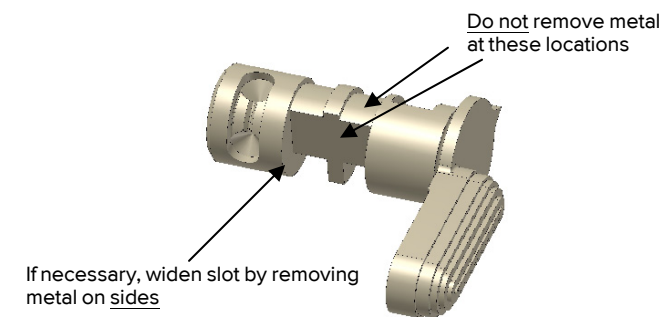

Figure 4 - Safety and locations for trimming safety slot

WEIGHT ADJUSTMENT OF 1ST STAGE

The next step is to pre-measure the trigger weight with a good quality trigger pull gage. Without the hammer installed

you will need to add a little under ¼ lb to the measured trigger pull to account for sear friction. For instance, if the trigger pull is measured at 3.8 lb (without the hammer) add 0.2 lb to this value which will be an estimated 4.0lb 1st stage weight once the hammer is installed.

For the Service Rifle trigger Geissele Automatics has provided a "5-Coil" trigger spring that will allow for about a 4 lb 1st stage without modification. The Match Rifle trigger spring will produce about a 2.2 lb 1st stage without modification. The match rifle 1st stage minimum weight is limited by the ability of the trigger to return through the first stage after pulling just to the 2nd stage then releasing. However, going below 1.5 lb is not recommended. The DMR trigger uses a trigger spring that has a weight in between the Service and Match springs. For tactical shooting with the Geissele DMR it is recommended to keep the 1st stage at 3.0lbs and set the 2nd stage to 1.25lbs.

1st stage weight on the three different types of triggers is adjusted by bending the legs of the trigger spring either up or down with a pair of pliers. The legs should be bent at a point just before the legs enter the coils that fit around the trigger pivot bosses.

After the 1st stage is adjusted to the shooters liking, push the Fitting Pin out by tapping a standard AR15 trigger pin into place so you can use the Fitting Pin to install the hammer. As the Fitting Pin slides out it will keep the trigger and disconnecter aligned properly. The standard AR15 pin measures about 0.154" while the standard GA pin is precisely ground to 0.1558" diameter +/- 0.0001".

After the standard pin is slid into the trigger, the hammer will be installed using the Fitting Pin in a manner similar to the trigger. Make sure to use the supplied hammer spring and not a worn or overly relaxed spring. Also make sure the hammer bore is lubricated with GA No.1 Oil. NOTE: The hammer spring legs rest on top of the trigger pin, not on the bottom of the receiver well. See Fig 3.

At this time place a small dab of the supplied GA No.2 Grease onto the sear surfaces and the top of the hammer tail where the disconnecter rides. GA Lube No.2 is a very tenacious, slippery grease with superior load bearing capacity. Although the GA trigger can be used dry, lubrication during break in will help to polish the sear surfaces.

SPECIAL INSTRUCTIONS FOR THE SERVICE RIFLE

In CMP sanctioned competitions such as National Trophy rifle matches and EIC matches there is a minimum trigger pull weight of 4.5lb. When setting up the pull weight on the Service rifle the gunsmith must realize that it is vitally important that the shooter experience no issues on Match Day when the weight of his weapon trigger is checked before the start of the match. Although the 2nd stage weight is easily increased on the Geissele Hi-Speed trigger doing this before a match may mentally discombobulate the shooter as he has been practicing for the match with a lighter pull weight and has become used to the lighter trigger pull. In order to consistently meet the 4.5lb minimum weight requirement the trigger must be set up slightly in excess of 4.5lb. Generally, a weight of 4.8 – 5.1lbs will always pick up the trigger weight regardless of individual

inspector techniques. This will also allow some leeway as the trigger pull weight will decrease slightly as the sear surfaces polish in. The recommended procedure is to set the 1st stage as close to 4lb as possible using a pull weight gage (not trigger weight). Then dial in a 1lb 2nd stage for a total pull weight of 5lb. The Geissele Hi-Speed trigger is designed to place most of the pull weight on the 1st stage so that the 2nd stage break does not disturb aim. Because of this weight differential and the 4.5lb minimum weight requirement a shooter cannot control a 2nd stage that is under 0.8lb. The shooter might feel that he can control a very light 2nd stage break during dryfire but during a match he will experience inadvertent and unexpected pull thru of the 2nd stage. Keep the 2nd stage at 1.0-1.2lb to start; if the shooter feels like he wants a slightly lighter 2nd stage it is a simple matter to take the supplied 0.050" Allen Key and lower the 2nd stage weight. As long as the 1st stage has been set to 4.0lb the total weight will not decrease below the 4.5lb minimum.

SEAR ADJUSTMENT

Every GA Hi-Speed trigger is factory pre-set for sear engagement in a precision fixture designed to simulate an AR15 receiver. This does not mean that the trigger adjustment procedure can be skipped. Factory pre-setting the sear is only intended to assist the gunsmith by making the adjustment process easier. The beauty of an adjustable trigger is that small receiver dimensional variations from nominal can be accounted for so that each trigger can be individually tuned to each unique receiver.

During the adjustment procedure you will notice the adjustment screws are difficult to turn. The screw threads are coated with a polymer compound which produces a prevailing torque that will keep the adjustment screws from loosening.

The first step in the adjustment procedure is to locate the 2nd Stage Weight Adjustment Screw as shown in Fig 5. This is the set screw that is located in the top of the disconnecter between the trigger tower and sear hooks. Using the smallest Allen Key provided with the Ancillary package (0.050") ensure that the screw is about ½-¾ of a turn below flush (the screw is already set this way from the factory). Doing this will put tension on the disconnecter spring and is necessary for correct sear adjustment. Insufficient spring tension on the disconnecter will not push up the disconnecter properly so that the disconnecter engages the hammer tail with consistency.

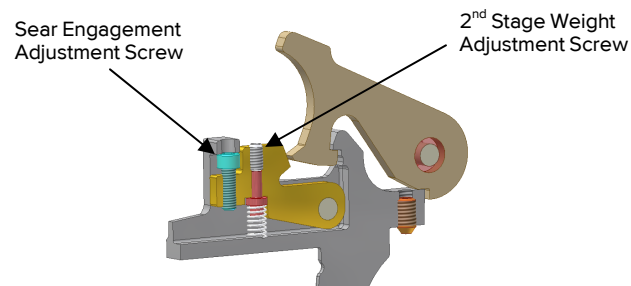

Figure 5 - Trigger Assembly (section view)

Now cock the hammer and locate the Sear Engagement Adjustment Screw as shown in Fig 5.

Pull the trigger while controlling the hammer and check for the presence of a 2nd stage. Since the GA trigger is factory pre-set for sear engagement you should feel a distinct stop as the end of the hammer tail contacts the disconnecter. Additional pressure to the trigger will cause the disconnecter to rotate slightly thereby letting the primary sear edges disengage. When the primary sear edges disengage the hammer will fall.

Using the supplied 5/64" Allen Key (the largest Allen Key supplied with the trigger), reach through the hole in the trigger tower and rotate the sear adjustment screw counter-clockwise (as in loosening the screw) in 1/8 turn increments while alternately cocking the hammer and pulling the trigger. Do this until the 2nd stage is lost. Do not let the hammer strike the lower receiver during this process. Keep your hand on top of the hammer or place a wadded up shop rag in-between the hammer and lower receiver wall to cushion the blow. Be careful, the full torque hammer spring will send the hammer forward with enough force to seriously bruise or injure your hand.

Now rotate the screw in the other direction (clock-wise) while alternately cocking the hammer, pulling the trigger and making a clock-wise adjustment to the sear screw until the 2nd stage is regained. The amount the screw should be turned clock-wise during this process is very small, perhaps 1/32 of a turn (10 deg).

When the 2nd stage is regained, the sear engagement adjustment screw is then additionally turned clockwise a little more than ¼ turn (about 110 deg). This is the initial sear setting point.

It is important when performing sear adjustment that the adjustment must always be backed off counter-clockwise past the point where the 2nd stage is lost and then turned clock-wise to regain the 2nd stage. Don't try to go counter-clockwise until the 2nd stage is barely lost and then try to adjust in the ¼ turn clockwise. If this is done there will be insufficient sear engagement.

A properly adjusted trigger should pivot smoothly through the 1st stage and come to a solid stop at the 2nd stage. If the trigger is "notchy" or feels like it is falling into a detent just as it comes up to the 2nd stage there is not enough sear engagement. Turn the sear adjustment screw clockwise in 5-10 degree increments until any notchy feeling is eliminated.

On the other hand, if any creep is felt in the 2nd stage, the sear adjustment screw can be turned in 5-10 degree increments counter-clockwise until the creep is eliminated. Usually, no more than one small nudge backward from the initial sear setting point is sufficient.

It is important to recognize that sear adjustment of the Geissele trigger is not a game in trying to adjust in as little sear engagement as possible. Insufficient sear engagement is the biggest cause of inconsistent trigger operation, pull through of the 2nd stage and wear of the sear ledges.

WEIGHT ADJUSTMENT OF 2ND STAGE

After the sear is adjusted properly, the 2nd stage weight adjustment screw is then turned with a .050" Allen Key (the smallest Allen Key supplied with the trigger) until the 2nd stage is at the desired weight. The screw is turned clockwise to increase the 2nd stage pull weight and counter-clockwise to decrease weight. Minimum weight is found when the top of the set screw is about ½ turn above the disconnecter top surface. Maximum 2nd stage weight is about two full turns in.

Turning the 2nd stage weight adjustment screw farther than 2 turns in will cause the disconnecter spring to coil bind during disconnecter operation. To check for coil bind, temporarily install the safety, pull the trigger back (and hold the trigger back) and re-cock the hammer while watching snap over of the hammer tail on the disconnecter. The disconnecter should snap over the hammer tail smoothly. If the spring is binding, the disconnecter will become stiff toward the end of its rotation causing the trigger to try and rotate forward against the shooters finger. If this occurs, the 2nd stage weight adjustment screw should be backed off until the disconnecter spring does not bind.

OVERTRAVEL ADJUSTMENT

Overtravel may be adjusted by means of the screw towards the front of the trigger. It is recommended to retain the maximum amount of overtravel possible. This will help prevent any movement of the rifle after the shot is fired from the moving trigger coming to a hard stop before the projectile has exited the barrel. The trade off with a long overtravel is a longer disconnecter reset when releasing the trigger. This is only a concern during rapid fire. If minimum overtravel is desired, pull the trigger fully back and partially rotate the hammer down while watching the clearance between the hammer sear edge and the trigger sear edge. Turn the overtravel adjustment screw clock-wise with a 1/16" Allen Key until the trigger is about 0.010" away from the hammer spur. This is the minimum adjustment position.

FINALIZE ADJUSTMENTS

Now cycle the trigger and hammer about 50 times (remember the lubrication of the sear surfaces). Re-check pull weight and make any necessary adjustments to the 1st and 2nd stages by dismantling the trigger and re-bending the trigger spring or by adjusting the 2nd stage weight screw. During this process of verifying the adjustments you can temporarily install the upper receiver and dry fire the weapon with the Fitting pin in the hammer and the standard AR15 pin in the trigger. Do not fire the weapon with the fitting pin installed.

Once trigger adjustments are completed, replace the Fitting Pin and the standard AR15 trigger pin with the larger Geissele Automatics pins. Remove the hammer before installing the GA pin into the trigger as the hammer spring legs hold and capture the trigger pin. The fitting pin can then be used again to re-install the hammer. Lube the trigger pins, trigger pin bore and disconnecter with GA No. 1 Oil before installing the pins. Just tap the pins into the holes so that the Standard AR15 Pin or GA Fitting Pin is pushed out the other side of the receiver. The hammer pin must be installed with the two grooves on the left side of the weapon

(the side with the bolt release). This will allow the internal circlip of the hammer pivot to capture the pin and keep the hammer pin in place.

When the trigger is fully assembled with the new Geissele pins, install the safety and pistol grip. Now readjust sear engagement per the above procedure to allow for any small differences in trigger component location due to the trigger and hammer pin replacement.

SAFETY AND FUNCTION CHECK

Assemble the upper receiver assembly to the lower receiver and check safety operation. With the hammer cocked and the safety lever in the "SAFE" position, pulling the trigger hard should not allow the hammer to fall. Check and make sure there is a gap of at least 0.015" between the hammer tail and face of disconnecter when the trigger is pulled with the safety on. If the gap is less than 0.015" do not fire the weapon and contact Geissele Automatics for a solution.

Now check the ability of the bolt carrier to re-cock the hammer. Pull the trigger and keep the trigger pressed back. Cycle the operating handle and let the bolt carrier snap forward. Release the trigger. The bolt carrier should have re-cocked the hammer and the hammer should not have followed the bolt carrier forward.

PERIODIC LUBRICATION, CLEANING AND MAINTENANCE

Keep the sear surface well lubricated for the first 200-300 rounds. It is recommended to always keep a small dab of fresh GA No. 2 Grease on the sear surfaces, especially on the match rifle trigger. However, after the initial break in period it is permissible to operate the trigger without lubricant. This will be helpful in dusty environments.

Every 500 rounds place a drop of GA No. 1 Oil on the sides of the disconnecter where the pin slides through and on the very ends of the hammer pivot next to the receiver walls.

When the lower receiver and receiver well become very dirty (such as by firing with a suppressor) it is not always necessary to remove the trigger group for cleaning. Spray down the trigger group with an electrical contact cleaner to remove residual oil and dirt. Next, use compressed air to blow off the trigger group and then flush liberally with a light lubricating oil such as CLP or CRC 3-36. Blow off excess oil with compressed air. Now apply GA No. 1 Oil and GA No. 2 Grease as above.

The trigger spring will last the life of the trigger and will not lose weight over time. The disconnecter spring should be replaced every 50,000 rounds. The hammer spring should be replaced every 10,000 rounds as this spring will break between 12-25,000 cycles. 12,000 cycles appears to be the original design fatigue life of the M16/AR15 hammer spring.

Contact Geissele Automatics with any questions.
 Bill Geissele - Geissele Automatics LLC
 1920 W. Marshall St., Norristown, PA 19403
 Tel: 610-272-2060 Email: whg@geissele.com
 Installation Instructions Rev 6b – 05 April 2009